

Technical specifications inserting newspapers 2021



Inserting

Reservation and orders

For the reservation of the insert in a title:

WEBSITE

www.mediahuis.be/adverteren

E-MAIL

for Limburg, Flemish-Brabant, Brussels and Wallonia:

pub@mediahuis.be

for Antwerp, East & West Flanders:

advertenties@mediahuis.be

A minimum of 3 weeks before publication (cancellation is possible up to 2 weeks before publication). Cancelling after this period will result in a penalty charge of € 25 per 1,000 copies.

Technical approval

Models or dummies of inserts must always be submitted to the planning manager of the print company for approval at least 6 weeks before the insert date. This is done to evaluate the product to be inserted and to investigate the possibility of including these in the planning. After all, it must first be checked whether the insertion of the insert is technically possible. The reservation of the insert is only final after the approval of the production management of the print company. The minimum number of models/dummies to be supplied for a test is 500.

For more information, please contact
print company planning manager:

Jos Castro, 011/71 71 77 - 0475/80 33 42

planningdrukcentrum@coldsetprintingpartners.be

Surplus

When ordering an insert, it must always be stated what should be done with any surplus of the insert: the surplus may be thrown away, or the surplus may be collected by the customer within 5 working days of the publication of the insert. The time of collection must be agreed with the planning managers of the print company.

Without prior notification, the surplus will always be destroyed.

Technical specifications

THE FOLLOWING INSERTS CAN BE PROCESSED

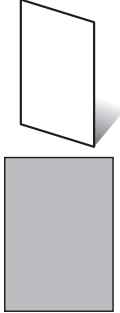
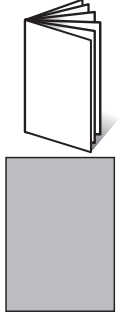
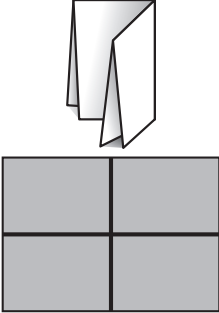
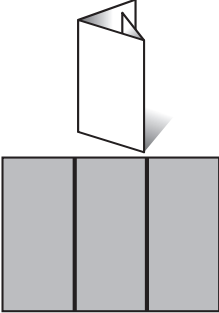
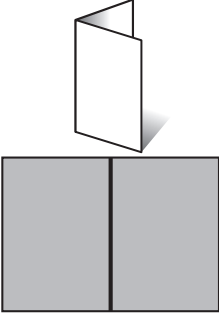
SINGLE SHEET	MAGAZINE/BROCHURE	CROSS-FOLD	WRAP-FOLD	MIDDLE FOLD
				

THE FOLLOWING INSERTS **CANNOT** BE PROCESSED

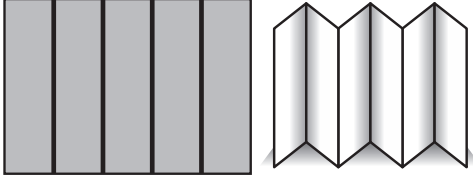
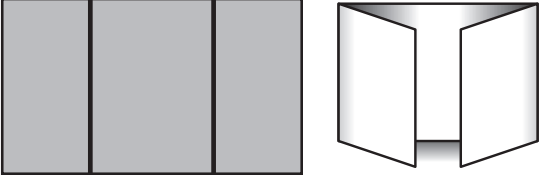
HARMONICA FOLD	ALTAR FOLD
	

Technical specifications

Format

MINIMUM FORMAT (finished product):

- 148 mm x 210 mm

MAXIMUM FORMAT (finished product):

- 275 mm x 400 mm
- 4-8 pages & single sheet, maximum format: 240 mm x 360 mm

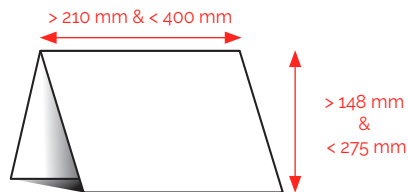

The longest side (= closed side) may not be more than twice as long as the shortest side.

Finish

- All inserts must have the same size and weight per m^2 .
- Maximum weight of one insert = 100 grams. Inserts with a weight of more than 100 grams are possible, but only after technical approval.
- If the outside of the insert is not printed, the insert must be provided on matt paper.
- Stick-on objects must be glued to the inside of the insert, and this against the top or bottom of the fold. Technical approval is required.
- If the insert is stapled, this insert must have a minimum thickness of the staple thread used. If this is not the case, the brochure must be glued (instead of stapled) with a maximum thickness of 1.5 mm.
- No adhesive glued back and no sewn straight back.
- It is better to avoid small-thick and large-thin inserts.
- Deviating inserts should always be discussed in advance with the planning manager in case of a possible technical investigation.

Paper grammage (indicative)

- Single sheet : from 200 grams/ m^2
- 4 pages : from 100 gram/ m^2
- 8 pages : 65 to 100 grams/ m^2
- 12-16 pages : 60 to 80 grams/ m^2
- More than 16 pages : 45 to 60 grams/ m^2
- Maximum 96 pages

Edition

The number to be delivered can be found in the rate sheets.

Inserts

Where to deliver

Printing Partners Paal-Beringen N.V.
t.a.v. Dirk Meeus
Industrieweg 147, 3583 Paal-Beringen
Tel. 011/71 71 13
E-mail: dirk.meeus@coldsetprintingpartners.be

When to deliver

- Mon to Fri 8:00 am - 4:00 pm
- Insert sheets are to be delivered to the print company 5 working days before the insert date (not earlier and not later).
- In the case of periodic inserts (weekly, monthly), different agreements can be made regarding delivery times. In that case, any delays in the production process for which CPP cannot be held responsible must be taken into account. Moreover, no guarantee can be given on the insertion of the entire edition.

Guarantees

In case of serious production-technical problems, we reserve the right to suspend insertion in order not to endanger the timely delivery of the parent product.

Packaging

- The inserts must be delivered as a finished product. See below, “Requirements for delivery”.
- All copies, in every package, must be stacked the same way; i.e. every last page lies on the front page of the next copy.



If you need to deliver models or dummies, this can also be done at the above address. The minimum number of models/ dummies to be supplied for a test is 500 copies.

EACH DELIVERY OF INSERTS MUST BE ACCOMPANIED BY A SHIPPING NOTE WITH AT LEAST THE FOLLOWING INFORMATION:

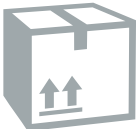

- Name of the customer
- Name and language of the respective edition
- Name of the insert
- Date of the insert
- Total number of inserts on the pallet
- Number of inserts per pack

If different versions of inserts are delivered for different editions, these must be separated for packaging and delivery. If the delivery does not take place according to the specification, the additional costs will be borne by the client.

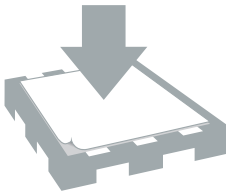
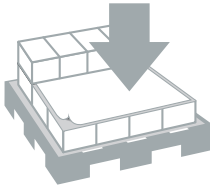
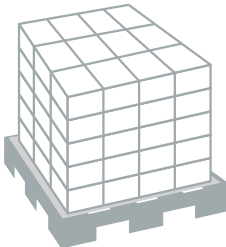
Delivery requirements

PACKING HEIGHT	NO PACKAGING	STABLE PALLETS	PROTECTIVE LAYER ON THE PALLETS	PROTECTION LAYER BETWEEN THE PALLET LAYERS	STRAIGHT STACKING
					
<ul style="list-style-type: none"> The packing height must be a <u>minimum of 10 cm</u> and a <u>maximum of 16 cm</u>. <ol style="list-style-type: none"> If a packing of 10 cm does not contain 75 copies, the height of the packing must be adjusted to a maximum of 16 cm. <u>The backs of the printed matter must be on 1 side of the packing</u> Ensure that all packings in one pallet layer are of the same height. A top and/or bottom sheet may not be used in the individual packings of printed matter. 	<ul style="list-style-type: none"> There must be no protective paper at the bottom of the packing. Do not tie the individual packings together nor wrap them in foil. A binding tape around the packings could damage the brochures. Copies may not be packed in boxes that are in turn stacked on a pallet. 	<ul style="list-style-type: none"> Pallet dimensions 120 x 80 cm (disposable). The pallets must be able to be handled on all 4 sides with a pallet truck or forklift. 	<ul style="list-style-type: none"> Place a sturdy sheet of cardboard on each pallet to protect the bottom layer from dirt or damage. A plastic sheet should also be provided when the pallet is wet. 	<ul style="list-style-type: none"> There should also be a sheet of cardboard between each pallet layer. This increases the stability when stacking the pallet. 	<ul style="list-style-type: none"> Stack the packings as closely together as possible. The packings should not protrude from the sides of the pallet. The packings must be of the same height per pallet layer. Straight stacking reduces the risk of damaging the brochures. <p><i>As an alternative to loose stacking of the inserts, pallet boxes can also be used (e.g. box with bottom dimensions: 77 cm x 118 cm - 102 cm height).</i></p>

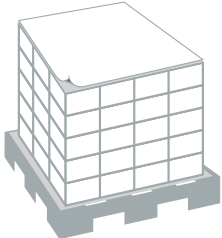
Delivery requirements

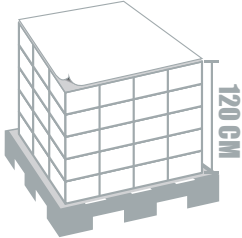
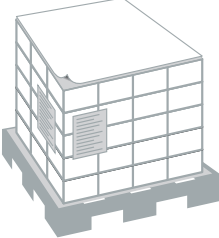
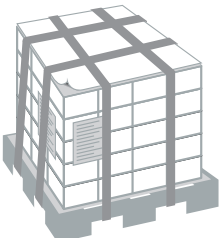
PROTECTION ON THE TOP OF EACH PALLET	PALLET WEIGHT: MAXIMUM 1,000 KG	PALLET HEIGHT: MAXIMUM 120 CM	IDENTIFICATION SHEETS	VERPAKKING VAN DE PALLETTEN
				
<ul style="list-style-type: none"> • If the pallets are not stacked on top of each other, it is sufficient to protect the top of the pallet with a sheet of cardboard. • If the pallets will be stacked, the top must be protected with a wooden cover. 	<ul style="list-style-type: none"> • One pallet may weigh a maximum of 1,000 kg. • A pallet that weighs more can no longer be manipulated using a pallet truck. 	<ul style="list-style-type: none"> • If the pallet height exceeds 120 cm, there will be problems with manual removal, and the stability of the pallet will be endangered 	<ul style="list-style-type: none"> • Apply to the short side and top of each pallet with the following data: <ul style="list-style-type: none"> • Name of the customer • Name and language of the respective edition • Name of the insert • Date of the insert • Total number of inserts on the pallet • Number of inserts per pack • Individual pallet number + total number of pallets of the edition • Weight of the pallet • Name (contact person), address and telephone number of the printer 	<ul style="list-style-type: none"> • You provide the pallet with cardboard pallet corners, after which you wrap the pallet with stretch film OR you provide the pallet with a wooden cover board at the top, after which you strap the pallet with 4 plastic straps (2 per direction). <p>PLEASE NOTE: no metal straps!</p>